

CARBONETIC Single carbon / metal clutch for Honda S2000
Instruction manual on changing the pull style to push style

Required parts (sold separately)

- * Mitsubishi slave cylinder MD748617
- * Nissan clutch bearing 30502-21000

CARBONETIC clutch kit accessories

- | | |
|------------------|--------------------|
| 1 Bearing sleeve | 2 Pivot |
| 3 Release fork | 4 Reverse Rod |
| 5 Dust boot | 6 Cylinder bracket |

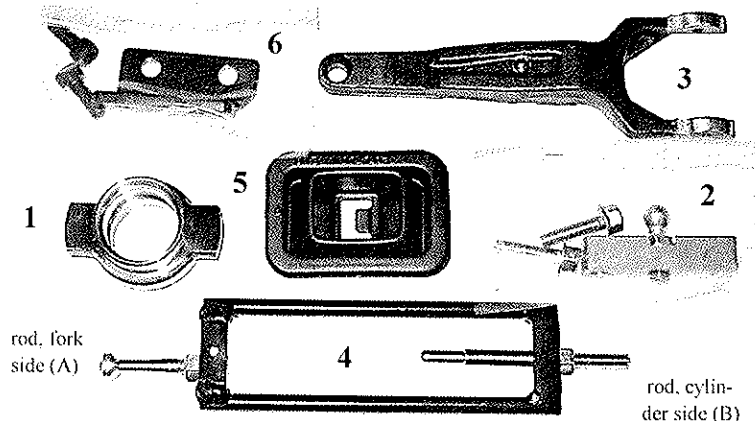

Pull style to push style Conversion process

- 1 Install the Nissan Bearing (30502-21000) into the CARBONETIC bearing sleeve.
- 2 Remove the stock pivot and install the CARBONETIC pivot. (diagram 2 shows the CARBONETIC pivot installed)
- 3 Apply grease on the pivot and install the CARBONETIC release fork into the opening in the clutch housing. Apply grease into the groove of the Nissan bearing, then install the bearing. (diagram 3). Use Honda genuine grease (08798-9002) or equivalent grease. Install the dust boot before the fork is connected to the reverse rod.
- 4 Modify the Mitsubishi slave cylinder. Please refer to the following page.
- 5 Assemble the slave cylinder, cylinder bracket, and reverse rod (tentative assembly) - refer to the following page
- 6 Install the transmission to the engine. Use of a transmission jack is always highly recommended. Refer to the S2000 service manual for the tightening torque of mounting bolts.
- 7 Install the slave cylinder to the mission housing - refer to the following page. Apply grease to the contact point of rod / release fork, and reverse rod / cylinder.
- 8 Connect the clutch hose to the slave cylinder
- 9 Bleed the clutch system then tighten the bleeder screw.

Attention: With CARBONETIC carbon clutch, the disengagement point of the clutch becomes deeper. This is not a malfunction. In order to compensate, adjust the rod which connects the clutch pedal and the master cylinder and reduce the free travel as much as possible. However, never make the free travel negative — (the rod always pressures the piston). Negative free travel causes a damage on the proper circulation of the clutch oil and results in the dislocation of the engagement point.

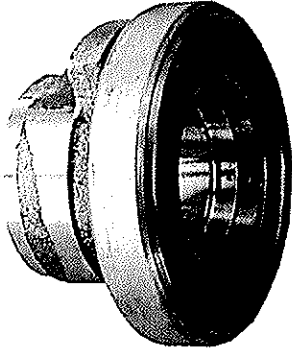

1) Nissan bearing with CARBONETIC bearing sleeve

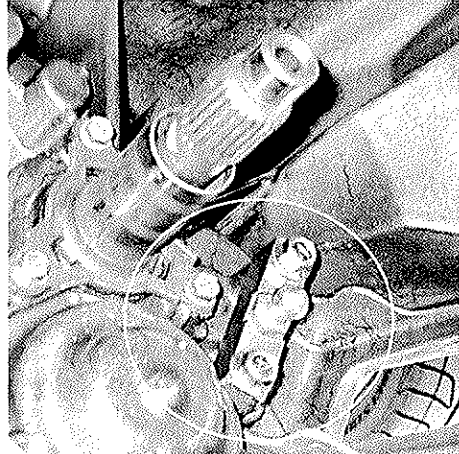

2) CARBONETIC pivot is installed

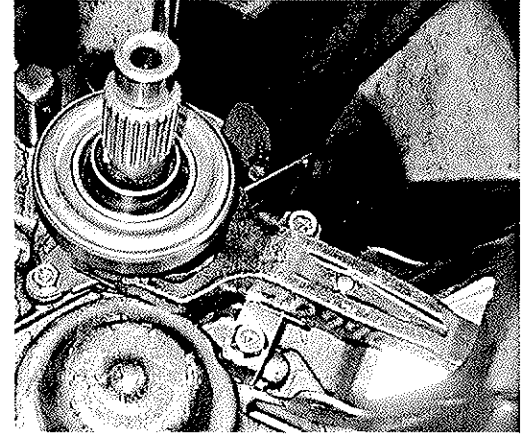

3) CARBONETIC release fork & bearing assembly

Slave cylinder and reverse rod assembly

Install the bracket and the slave cylinder to the transmission with fine adjustment so that the release fork and the rod form a right angle (90 degrees)

A view from the bottom toward the slave cylinder

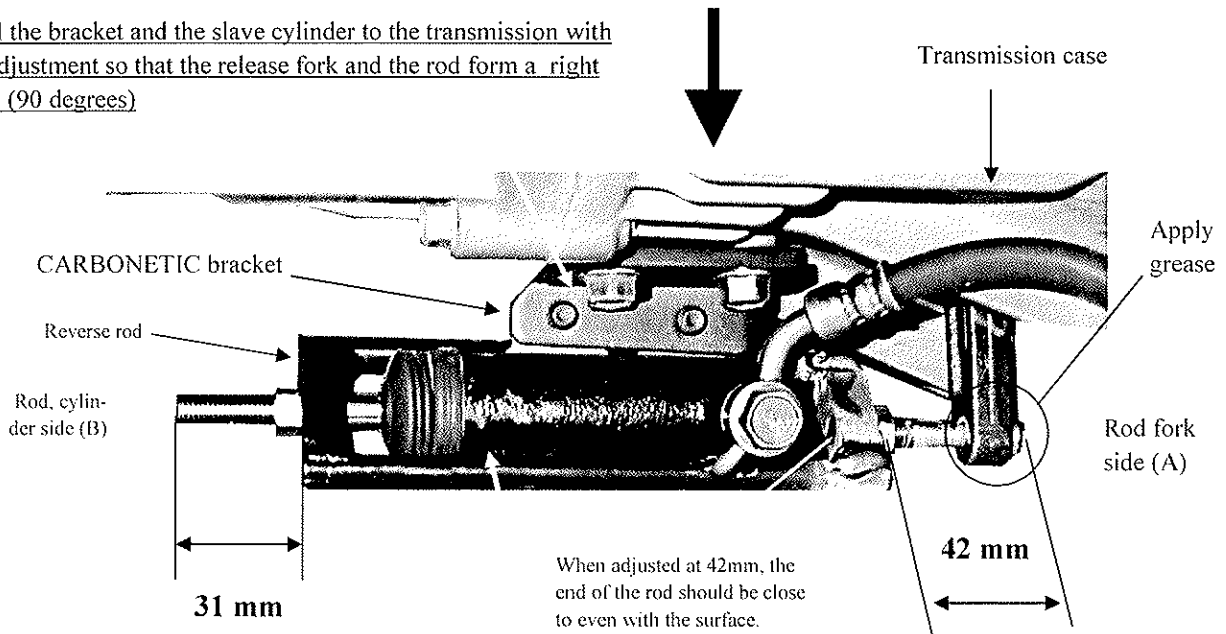

Adjust the rod so that the distance from the top of the rod to the end section (surface) of the reverse rod is set to **31 mm (this number is revised from the original Japanese manual)**

Modified Mitsubishi slave cylinder. Refer the next page for the modification

Adjust the rod so that the distance from the top of the rod to the end section (surface) of the reverse rod is set to **42 mm (this number is revised from the original Japanese manual)**

Modification of Mitsubishi slave cylinder

- 1 Remove the fitting at the fluid entry port
- 2 Discard the valve and the spring in the entry port — refer to the diagram below
- 3 The location of the bleeder valve and the fluid entry port will be reversed in the assembly. After removing the bleeder valve, **prepare the entrance smooth and flat by sandpaper in order to secure the tight seal.** The stock Honda entry fitting (end of the clutch hose) will be attached here. If it is not airtight, oil leakage might cause a malfunction of the clutch. Please pay the extra attention to prepare the port. - refer to the diagram below
- 4 Install the stock entry fitting (end of the clutch hose) using the stock banjo bolt, two washers which come with the Mitsubishi slave cylinder and one CARBONETIC washer.
- 5 Attach the bleeding valve to the original fluid entry port.
- 6 **If there is any oil leakage, re-prepare the surface and / or change the number of washers until the leakage is eliminated.**

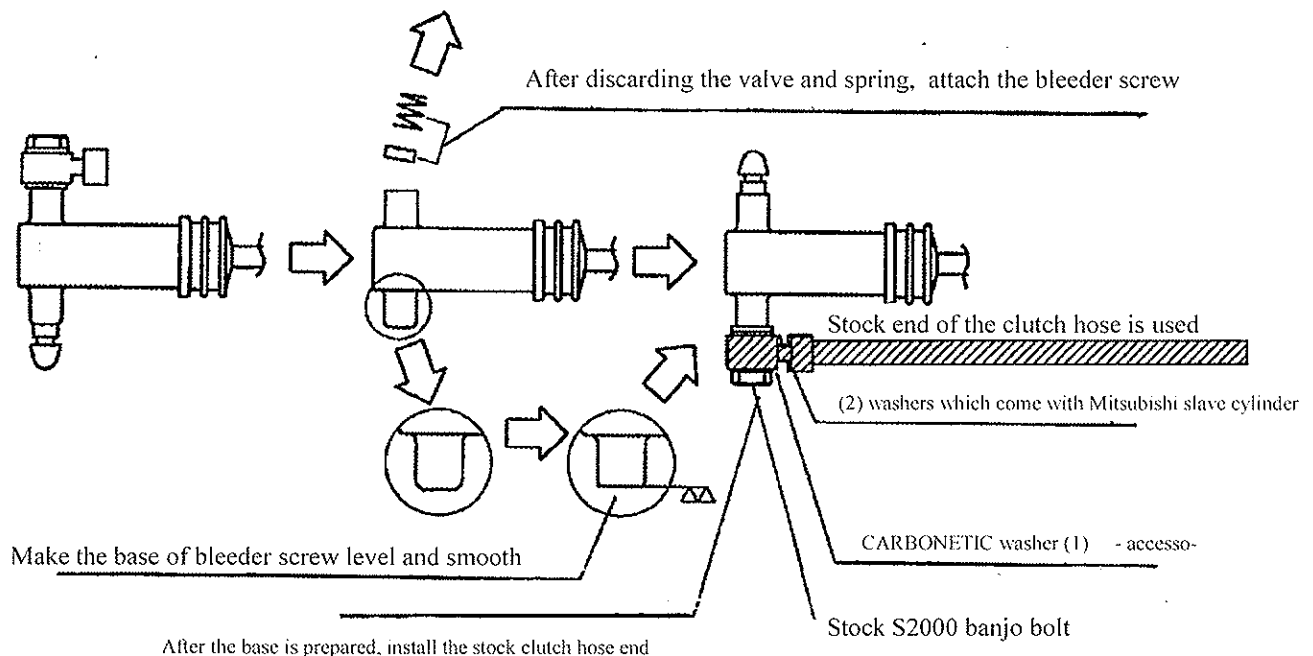

Clutch

Clutch Pedal, Clutch Pedal Position Switch, and Clutch Interlock Switch Adjustment

NOTE:

- To check the clutch pedal position switch (see page 4-47).
- To check the clutch interlock switch (see page 4-6).
- The clutch is self-adjusting to compensate for wear.
- If there is no clearance between the master cylinder piston and push rod, the release bearing is held against the diaphragm spring, which can result in clutch slippage or other clutch problems.

1. Loosen locknut (A), and back off the clutch switch (B) until it no longer touches the clutch pedal (C).

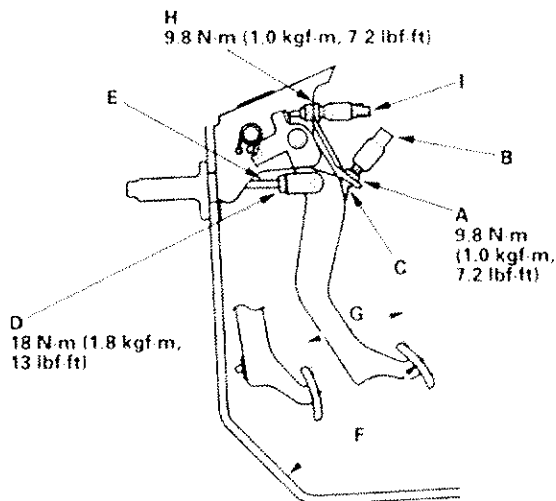

2. Loosen locknut (D), and turn the push rod (E) in or out to get the specified height (F) and stroke (G) at the clutch pedal.

Clutch Pedal Stroke: 115 - 125 mm (4.53 - 4.92 in.)
Clutch Pedal Height: 189 mm (7.44 in.)

3. Tighten locknut (D).
4. With the clutch pedal released, turn the clutch pedal position switch (B) in until it contacts the clutch pedal (C).

5. Turn the clutch pedal position switch (B) in an additional 3/4 to 1 turn.
6. Tighten locknut (A).
7. Loosen locknut (H) and the clutch interlock switch (I).
8. Press the clutch pedal to the floor.
9. Release the clutch pedal 15 - 20 mm (0.59 - 0.79 in.) from the fully depressed position, and hold it there. Adjust the position of the clutch interlock switch (I) so that the engine will start with the clutch pedal in this position.
10. Tighten locknut (H).

This is a copy of the service manual for S2000. With CARBONETIC clutch, the clutch disengagement point becomes deeper. Adjust the G & F so that the clutch pedal returning point becomes higher than the original point.

CARBONETIC carbon / metal clutch installment to Honda S2000

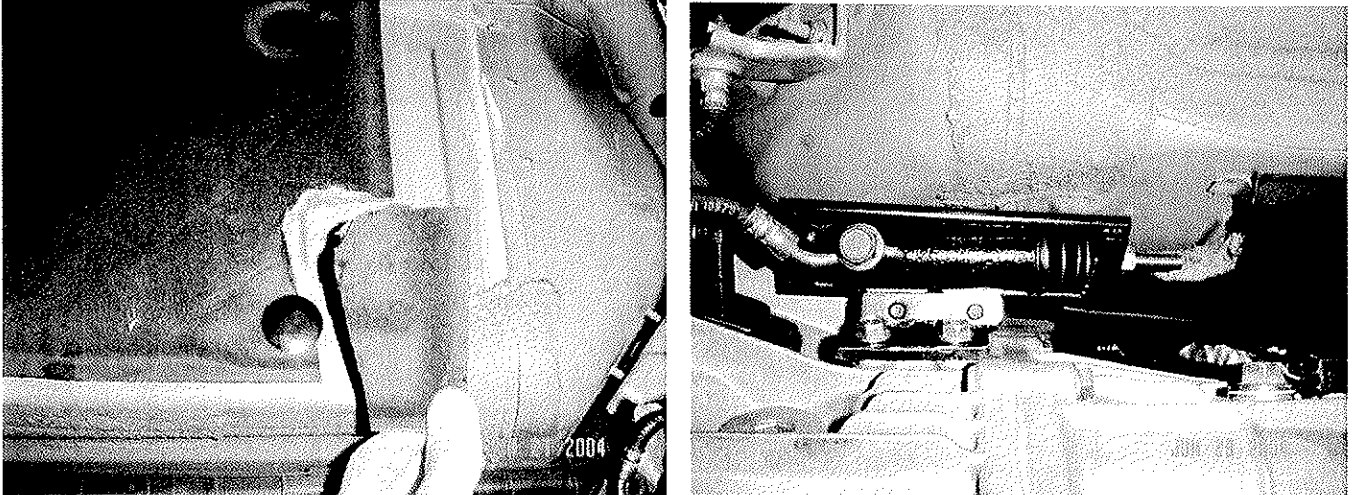

In order to install CARBONETIC carbon / metal clutch to Honda S2000, it is necessary to cut the protective shield to avoid the interference with the reverse rod. Please refer to the pictures above.

Also please note that

CARBONETIC carbon / metal clutch is build with the performance as the primary objective. It is extremely light. However, due to this lightness, harmonics vibration is picked up at certain RPM range (2,500 to 3,500 rpm). ATS&ACROSS offers a heavier flywheel as an option to mitigate this harmonics vibration and other noises.

The clutch engagement point becomes much earlier than the stock. (closer to the floor)